

TANK INTERFACE APPLICATIONS FOR THE KAM[®] OWD[™] SENSOR

Utilizing the KAM[®] OWD[™] Oil Water Detector to determine the vertical distribution of fluids inside a tank provides real-time data for optimizing the separation process.

KAM Controls Tank Interface Detection offers you REAL-TIME monitoring of:

- Tank oil layer level
- Tank emulsion layer level
- Tank water layer level

KAM Controls Tank Interface Detection saves you time and money.

- No costly shutdowns
- Maximum chemical efficiency
- Maximize heat/energy efficiency

KAM Controls sensor offer unmatched flexibility and ease of installation.

KAM[®] OWD[™]
OIL WATER DETECTOR
with 2" MNPT seal housing

Also available with 2", 3", or 4"
flanged seal housing.



KAM[®] OWD[™]
OIL WATER DETECTOR
flow through model
available with
1/2", 3/4", 1", or 2" FNPT

Also available in metric sizes.



TANK INTERFACE APPLICATIONS FOR THE KAM® OWD™ SENSOR

Installation options for KAM® Tank Interface Detection include OWD™ flow-through sensors on sample lines or three individual tank-mounted OWD™ sensors and can be configured and installed according to your needs and your budget.

The sample line configuration incorporates three sample lines drawing from the water, emulsion, and oil layers. Each line has its own draw-off valve and flow-through OWD™ sensor.

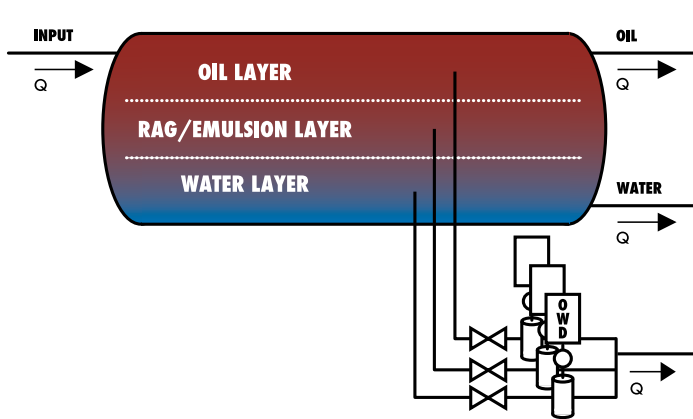

HORIZONTAL TANK

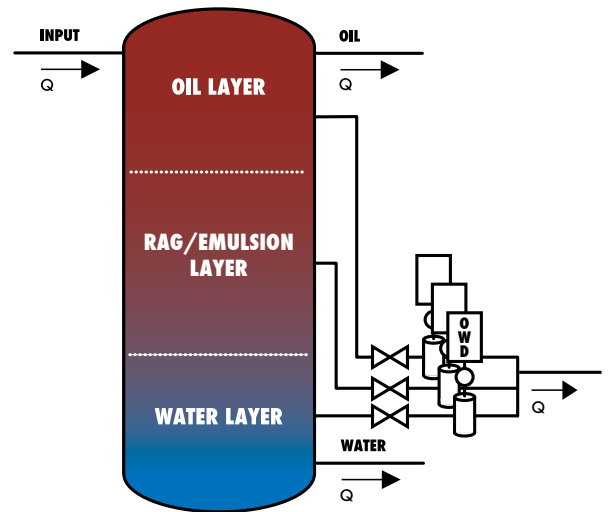

VERTICAL TANK

An additional configuration utilizes three OWD™ sensors inserted directly into the tank to detect levels at the oil layer, emulsion layer, and the water layer.

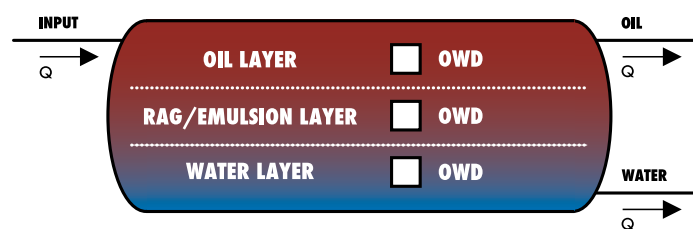

HORIZONTAL TANK

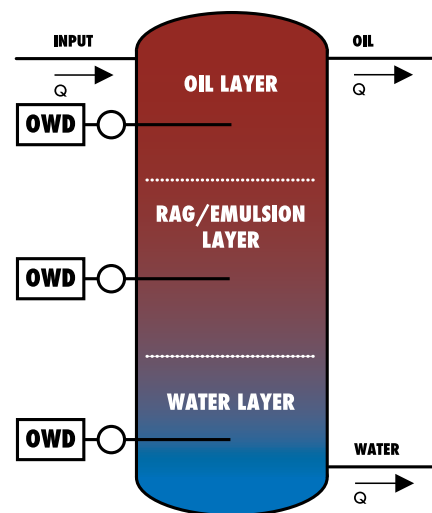

VERTICAL TANK

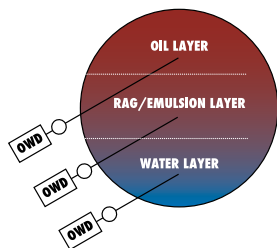

HORIZONTAL TANK CROSS SECTION