

KAM[®] OWD[®]
WATERCUT METER

PTB 08 ATEX 2016 Issue 01
IECEX PTB EX 19.0048
Ex db IIB T6 Gb



Using multiple microwave frequencies, the patented multi-antenna design of the KAM[®] OWD[®] ensures consistent accuracy across the entire 0-100% range.

KEY FEATURES

- 0-100%, 0-40%, 0-20% ranges
- $\pm 1\%$ full scale accuracy
- Automatically detects transitions between oil-continuous and water-continuous modes with optimized measurement/antennas for each mode
- Automatic temperature correction
- All requisite electronics housed within unit

With high accuracy across the entire calibrated range, the rugged KAM[®] OWD[®] Watercut Meter is the ideal instrument for measurement in high-water applications, including production monitoring, test separators, automatic well test, allocation, and more. The OWD[®] detector offers continuous, real-time data with $\pm 1\%$ of full range accuracy. Two antennas, operating independently of each other at separate, locked microwave frequencies, are optimized for both oil-continuous and water-continuous flows. The effect is of two instruments operating in parallel and providing comparative data to a single microprocessor for absolute accuracy, regardless of water concentrations, emulsions, etc.

The OWD[®] also automatically corrects for changes in temperature, and can be calibrated to any salinity. Measurement is fully automatic with no need for operator intervention or supervision.

KAM products are bench made at the factory in Houston, Texas and all parts are made, machined and assembled in the USA. The simplicity of design and quality of engineering employed in the OWD[®] detector mean there are no moving parts. All the requisite electronics are incorporated into the unit itself, with no need for separate controllers. The output signal can be sent to Flow Computers, SCADA, PLC's or to a Central Control Room for logging or display on chart recorders or monitors.

Insertable sensors can be inserted directly into the pipeline under process conditions, avoiding costly shutdowns. Flow through models are also available for 1", 2" and 3" pipelines.

AVAILABLE MODELS

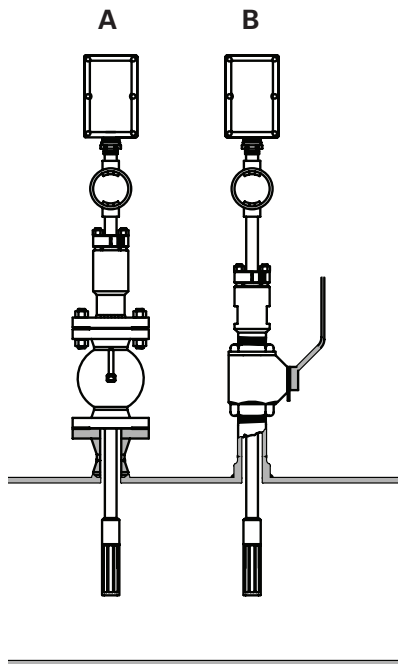

A: OWD® Insertable model installed on a main pipe with 2", 3", or 4" flanged seal housing

B: KAM® OWD® Insertable installed on a main pipe with 2" MNPT seal housing

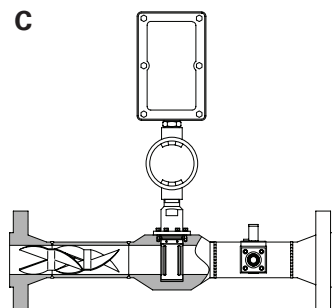

C: KAM® OWD® Spool on 1", 2" or 3" seamless pipe with weld-neck flanges; Integrated KAM® SMS® Static Mixing Spool; ½" sample valve with ½" pitot probe

SPECIFICATIONS

Media:	Crude oil
Ranges:	0-20%, 0-30%, 0-40%, 0-100%
Accuracy:	1% of full range
Repeatability:	± 0.01%
Resolution:	± 0.01%
Power:	24 VDC/1 amp at 24 watts (110/220 conversion available)
Pressure ratings:	ANSI 150, 300, 600, 900, 1500
Material:	Wetted parts – SS316, hastelloy, PEEK (Optional NACE MR-01-75 Compliance Available)
Fluid temp:	-40° to 176°F (-40° to 80°C) High temp model available to 600°F (315°C) Fluids below 32°F may require heat tracing
Electronics temp:	-40° to 158°F (-40° to +70°C)
Hazardous areas:	PTB 08 ATEX 2016 Issue 01 IECEX PTB EX 19.0048 Ex db IIB T6 Gb
Sensor dimensions:	Ø1.5" x 6.62" max (38 mm x 168 mm)
EX enclosures:	Sensor electronics - 3" x 6" x 3" (76mm x 152mm x 76mm)
Shaft length:	Off-the-shelf: 12", 24", and 36" (305mm, 610mm, 915mm) Additional lengths available
Pipe Size:	½" to 72" (15mm to 1829mm)
Weight:	from 20 lbs. (9kg)

FOR MORE INFORMATION ON KAM PRODUCTS

Phone: +1 713-784-0000

Fax: +1 713-784-0001

Email: sales@kam.com

www.KAM.com