



Simple Precision™



An ISO 9001:2015 certified company

## KAM® HOMOGENIZER

**TEL** +1 713 784-0000  
**FAX** +1 713 784-0001  
**Email** Sales@Kam.com

User Manual  
HOMOGMANUAL-0914

KAM CONTROLS, INC.  
3939 Ann Arbor Drive  
Houston, Texas 77063 USA  
[www.KAM.com](http://www.KAM.com)

# TABLE OF CONTENTS

<b>SECTION</b>	<b>TITLE</b>	<b>PAGE</b>
<b>1</b>	Warranty	2
<b>2</b>	Introduction	3
	•Available Models and Options	3
	•Theory of Operation	4
	•Specifications	4
<b>3</b>	Assembly and Operations	5
	•Stand and Drive Unit Assembly	5
	•Connecting the Generator to the Drive Unit	6
	•Running the Generator Within a Container	7
<b>4</b>	Maintenance	8
	•Cleaning	8
	•Dismantling the Generator	8
	•18mm x 200mm Generator Assembly	9
	•25mm x 200mm Generator Assembly	10
	•Reassembly of the Generator	11
	•Drive Unit Maintenance	11

KAM CONTROLS, INC. reserves the right to make changes to this document without notice.

# **WARRANTY**

## **WHAT IS COVERED**

KAM CONTROLS, INC. warrants that the instrument will be free from any defect in parts or workmanship and will, at its option, replace or repair any defective part (excluding consumables) or instrument.

## **FOR HOW LONG**

This warranty remains in effect for 1 year from the date of delivery to the original purchaser.

## **WHAT IS NOT COVERED**

This warranty will be null and void if the user fails to follow all instructions on the instrument, in the Operators Manual, and in the software, including, but not limited to:

- timely replacement of consumables
- adherence to recommended operating procedures

This warranty does not cover consumables (as defined in Operators Manual) or part or workmanship which have been damaged due to:

- Neglect, abuse, or misuse
- Damage caused by or to test samples
- Damage incurred during instrument relocation
- Damage caused by or to any attached equipment
- Use of incorrect line voltage or fuses
- Improper or unauthorized repair, or
- Any other damage caused by purchases or its agents, and
- Fire, flood, "acts of God" or other contingencies beyond the control of KAM CONTROLS, INC.

## **RESPONSIBILITIES OF PURCHASER**

To ensure warranty coverage, purchaser must:

- Return the warranty registration card
- Use the instrument according to directions (see Operators Manual)
- Connect the instrument properly to a power supply of proper voltage
- Replace blown fuses
- Perform routine maintenance as specified in the Operators Manual

## **HOW TO GET SERVICE**

Purchaser should contact the Service Department of KAM CONTROLS, INC. for warranty service information and for proper carting and shipping instructions. A return authorization number must be issued prior to returning shipments to KAM CONTROLS, INC. for repair or otherwise.

## **WARRANTY DISCLAIMER**

KAM CONTROLS, INC. hereby excludes and disclaims any warranty of merchant liability or fitness for any particular purpose. No warranty, express or implied, extends beyond the face hereof. KAM CONTROLS, INC. shall not be liable for loss of use of instrument or other incidental or consequential costs, expenses or damages incurred by the purchaser or any other user.

## **PURCHASER'S RIGHTS UNDER STATE LAW (U.S. ONLY)**

This warranty gives the purchases specific legal rights, and the purchaser may also have other rights which vary state to state in the United States.

# INTRODUCTION

## AVAILABLE MODELS and OPTIONS

KAM Homogenizer parts are sold separately.

Homogenizer Drive Unit  
(part # KAM 09014)

Dispersing Tool/Generator

Available in three sizes:

10mm diameter for 10 to 50 ml Volume (KAM 09012)

20mm diameter for 50 ml Volume (KAM 09019)

30mm diameter for larger containers (KAM 09009)

24" Laboratory Stand  
(KAM 09018)



# INTRODUCTION CONTINUED

## THEORY OF OPERATION

The KAM Homogenizer is designed to disperse and emulsify organic and inorganic materials in a liquid/liquid, liquid/solid, or solid/solid state. It has the necessary torque to process difficult samples, and because it's lightweight, it can be used in a mounted position for hands-free homogenization and/or as a handheld homogenizer.

During operation, the medium to be processed is pulled into the bottom of the tube by the rotor and forced out the sides through the stator slots. The stator acts first of all as an ideal flow breaker and prevents, to a large extent, the rotation of the medium, allowing the introduction of large mechanical energies in a very small space. The vortex formation common in stirring is greatly reduced but cannot be avoided altogether. In the shearing gap between the rotor and stator, approximately 1000 times more energy is introduced into the medium than would be with stirring. The particles are pulled into the center of the rotor and then forced radially outward. In this process the particles, by hitting sharp edges and by cavitation, are reduced in size. It usually takes only a few minutes to obtain a fine particle size reduction. Longer processing times achieve only an insignificant improvement in particle size reduction, while increasing the temperature of the medium through the energy input.

## SPECIFICATIONS

Angular Velocity Range in RPM:	Variable speed 10,000-30,000 rpm
Dimensions (drive unit):	Height 8.5", Width 2.75" (216mm x 70mm)
Dimensions (stand):	Height 24", Width 7", Depth 8.25" (610mm x 178mm x 210mm)
Weight (drive unit):	2.1 lbs (1.4 kg)
Weight (stand):	12 lbs (5.4 kg)
Power Requirements:	120 Volts, 50/60 Hertz, 4.8 Amps
Wattage:	576
Noise Rating:	72dB

# ASSEMBLY and OPERATIONS

## STAND AND DRIVE UNIT ASSEMBLY

1. Attach the two side legs to the back leg using the four (4) 3/8-16 x 2 1/4 socket head cap screws included.
2. Install the leveling screw assembly into the threaded hole located in the top of the left leg.
3. Make sure that the three (3) rubber feet are located in the other three corners of the legs.
4. Insert the 24" long support post (cord holder end upward) into the hole located at the back of the base, and tighten the 3/8 hex bolt and jam nut.
5. Open one side of the post clamp and insert it onto the post and tighten in place.
6. Screw the cross-rod assembly into the threaded hole located in the back of the drive unit.
7. Once the cross rod is threaded into the rear of the drive unit, tighten the jam nut, locking the cross rod in place.
8. Insert the drive unit with the cross rod attached into the post clamp and tighten.
9. With the drive unit in place on the stand, insert the power cord into the end cap located in the upper end of the post.
10. Once the stand and drive unit have been assembled and the electrical connections checked, the drive unit may be tested. Do not use a generator at this time.

### CAUTION:

Running a generator or chamber assembly without liquid media can cause damage to the bearings, unless the lower bearing of the generator has been replaced with a sealed and shielded stainless steel bearing.

# ASSEMBLY and OPERATIONS CONTINUED

## CONNECTING THE GENERATOR TO THE DRIVE UNIT

1. The generator is fitted into the drive unit by inserting the upper end of the generator into the collar end of the drive unit. Fig. 2-1.
2. Align the slots in the generator with the locating pins in the drive unit collar by gently rotating the generator as you insert it into the collar.
3. Once aligned, push the generator inward as far as possible and turn the generator clockwise 1/4 turn. The collar is spring loaded and some resistance is normal. Fig. 2-2
4. Having turned the generator as far as it will go, release the generator. You should hear a distinct click as the generator drops into its locked position.
5. To disconnect the generator, push it up into the drive unit collar as far as possible and turn it clockwise 1/4 turn.

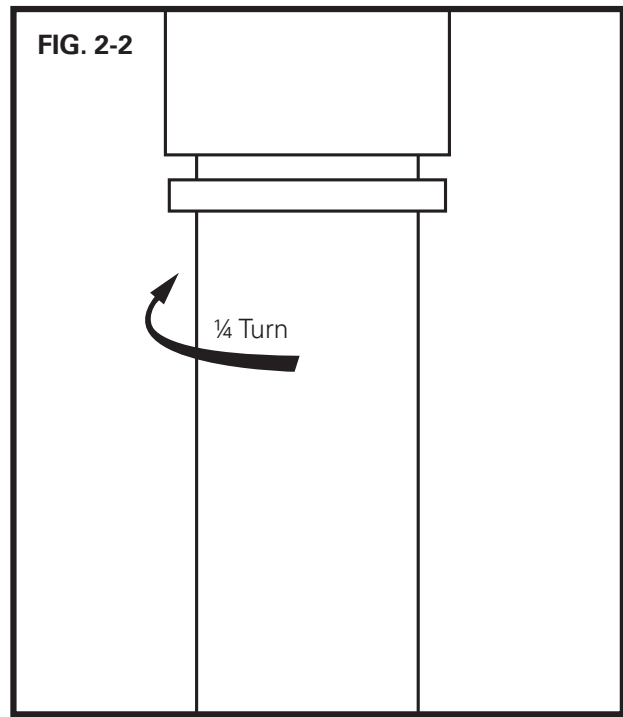
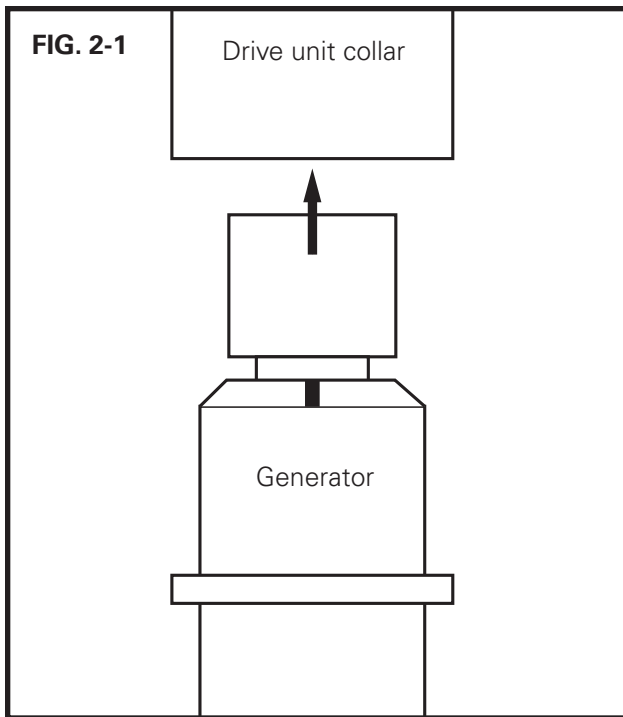

# ASSEMBLY and OPERATIONS CONTINUED

## RUNNING THE GENERATOR WITHIN A CONTAINER

1. The motor and generator may be used as either a hand-held unit or mounted to the stand.
2. Ideally, the diameter of the generator is as large as the container will allow.
3. Insert the generator into the medium that is to be homogenized. The normal insertion depth would be 1/2 to 1/3 the height of the medium measured from the bottom of the container. Heavier sediments may require lower positioning, but the generator must never come in contact with the bottom or sides of the container.
4. Start the drive unit at the lowest possible speed and then slowly increase the speed to the desired level.
5. If you are working with solid/liquid mixtures, add the solid material once the desired speed has been reached.
6. If you are holding the motor unit, it is advisable that you raise and lower the generator within the medium as you are processing the sample. This will help in speeding up the homogenizing process.
7. If the motor is mounted to the stand, it is advisable that the generator be immersed within the container off center. This off-center location will help minimize vortexing as well as the undesirable introduction of air into your sample.
8. The generators have two (2) sets of venting holes. One set is located approximately 1" from the bottom of the generator and the second set is approximately 1" below the bottom of the generator collar. The lower hole aids in keeping the lower bearing lubricated, while the top hole allows venting of any liquid that might be forced up into the tube. There is no need to avoid liquid from entering the lower set of holes.
9. Once you have reached the required level of processing, start to slowly remove the generator from the container while the motor is still running. It is important that this be done slowly as you want to spin all the medium from the generator back into the container and not outside of the container.
10. After spinning the medium off the generator, the motor can be turned off and the generator totally removed from the container.

### **WARNING:**

Never attempt to hold the lower end of the generator while the generator is attached to the motor.



# MAINTENANCE

## CLEANING

1. Immediately after finishing work with the apparatus, the generator must be cleaned so that substance residues cannot stick to the rotor and stator and allow small bacterial cultures to form in undesirable places. For this purpose, the generator should be run in a solvent which dissolves any residue and does not harm the generator components. The rotor and stator are cleaned as the solvent is pumped through the generator.
2. The generator can be sterilized by any one of 4 processes:
  - A. Germicidal solutions (formalin, phenol, alcohol, etc.) can disinfect in most cases. However, any germicide residue must subsequently be removed with sterilized water.
  - B. Steam at a pressure of 2 bar above atmospheric and a temperature of 120°C.
  - C. Hot air at a temperature of 160° to 190°C.
  - D. Flaming. However, it is only affective on external surfaces.

## DISMANTLING THE GENERATOR FOR CLEANING AND REPAIR

See FIGS. 3-1, 3-2

1. Remove the rotor shaft collar assembly (1) from the end of the generator by loosening the set screw located in the side of the rotor shaft collar using the 5/64 hex wrench supplied in the tool kit.
2. Remove the nylon washer (3) from the top of the generator assembly.
3. With the rotor shaft collar assembly (1) and the nylon washer (3) removed, slide the rotor shaft (2), the rotor knife(8), and the lower bearing (7), as an assembly, off the lower end of the generator.
4. To remove the rotor knife (8) and the lower bearing (7), attach the rotor shaft collar (1) to the upper end of the rotor shaft (2). With the rotor shaft collar attached, insert the 1/4" hex wrench into the end of the rotor shaft collar and with the screwdriver inserted through the rotor knife, turn the hex wrench counterclockwise. This will remove the rotor knife from the rotor shaft and allow the lower bearing to be removed. The lower bearing should be replaced before the blade is allowed to come in contact with the inside wall of the generator tube.
5. To clean, rinse the generator in a cleaning material or solvent. The solvent must not attack stainless steel or PTFE. For a thorough cleaning, the generator must be dismantled, as the medium also wets the inner wall of the tube.
6. After cleaning, sterilization methods A, B, or C are suitable for sterilizing the generator.

# MAINTENANCE CONTINUED

**FIG. 3-1** 18MM X 200 MM GENERATOR

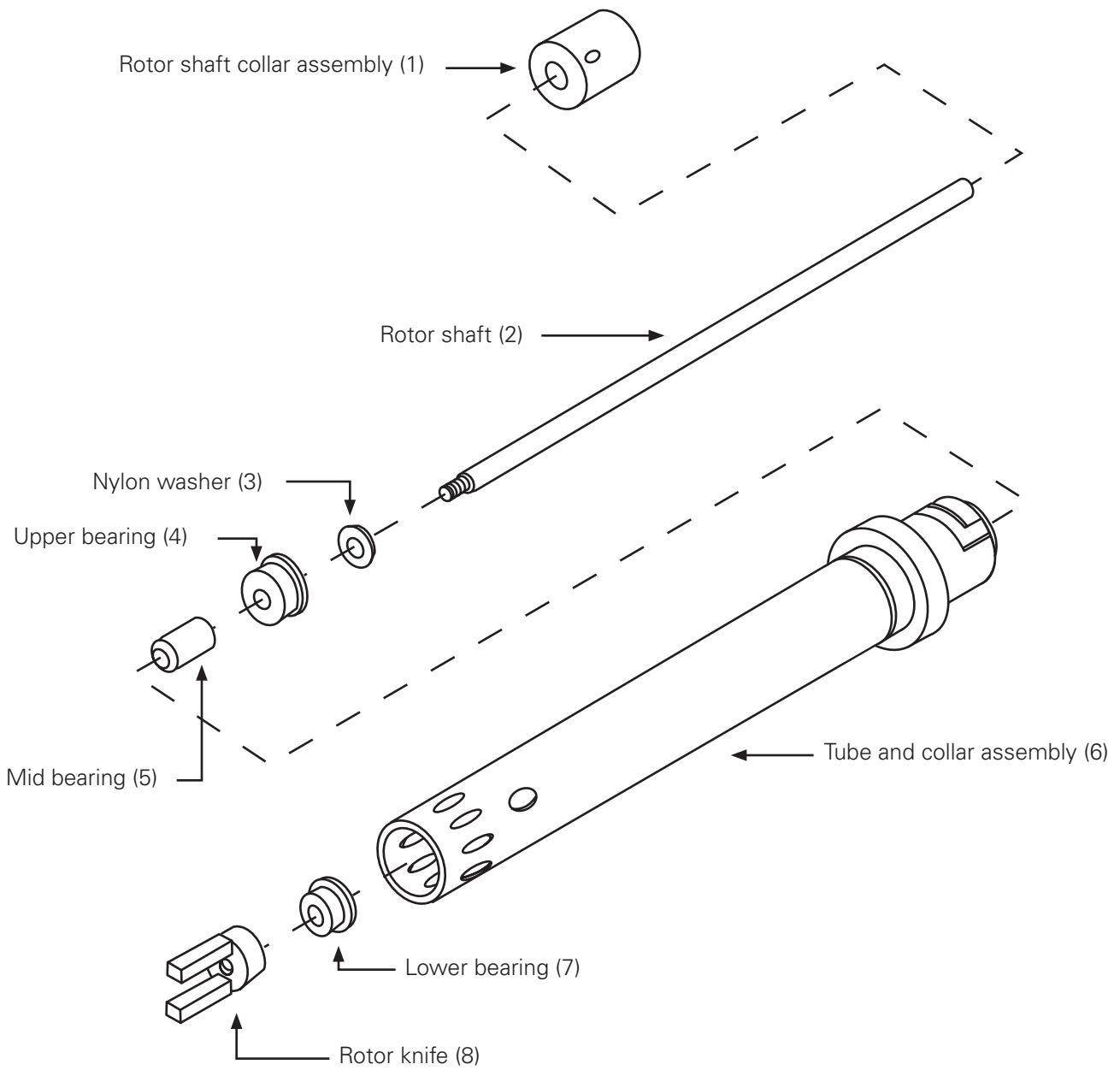

# MAINTENANCE CONTINUED

**FIG. 3-2** 25MM X 200MM GENERATOR

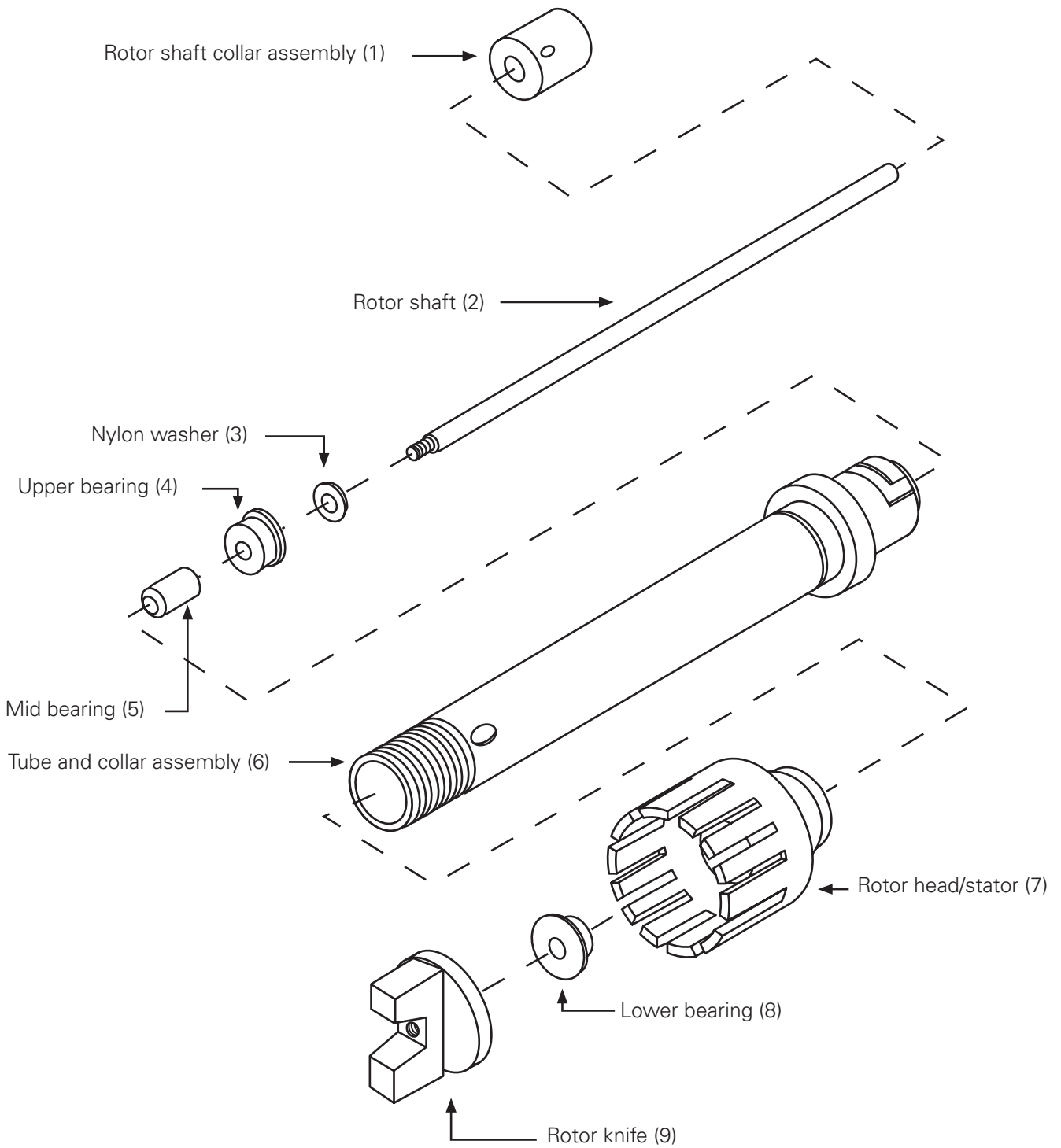

# MAINTENANCE CONTINUED

## REASSEMBLY OF THE GENERATOR

1. Slide the lower bearing (7) onto the end of the rotor shaft (2), and then screw the rotor knife (8) onto the end of the shaft and finger tighten.

**CAUTION:** over tightening of the rotor knife onto the rotor shaft can result in the shaft breaking and/or distortion of the rotor knife.

2. Insert the upper bearing (4) into the top of the tube and collar assembly (6). The bearing is properly positioned when the flange of the bearing is flush against the top of the tube and collar assembly.
3. Insert the assembly from Step 1 into the bottom end of the tube and collar assembly and push it upward until it passes through the upper bearing.
4. Once the shaft assembly has been inserted into the tube and collar assembly, place the nylon washer (3) on the end of the shaft which is extending through the upper bearing.
5. Stand the generator assembly on a flat surface with the blade end downward. Push the rotor shaft collar assembly (1) downward onto the end of the shaft until the nylon washer is in contact with both the bottom of the rotor shaft collar assembly and the top of the upper bearing. Tighten the set screw located in the side of the rotor shaft collar assembly and check that the generator rotates freely.

## DRIVE UNIT MAINTENANCE

The brushes should be inspected frequently when the unit is used continuously. If your motor unit runs sporadically, loses power, makes unusual noises or runs at a reduced speed, check the brushes.

**WARNING:** To continue using the drive unit in this condition will permanently damage the motor.

To check the brushes, with the cord unplugged, remove the drive unit top cap and check both brushes one at a time. If the brush is less than 1/8" long or the end surface of the brush that contacts the commutator is rough and/or pitted, it should be replaced. Usually the brushes will not wear out simultaneously. However, if one brush is worn, replace both brushes. Make sure that the brushes are installed properly. The curved surface of the brush must match the curvature of the commutator. After replacing the brushes, the motor should be run at no-load. Place the drive unit on a clean surface and run it freely for 5 minutes at approximately half speed. This will allow the brushes to seat properly and will increase the lifetime of each set of brushes. This will also extend the total life of the motor since the commutator surface will wear longer.

### **WARNING:**

The KAM Homogenizer drive unit is supplied with sealed ball bearings and requires no additional lubrication.

Any service of the drive unit other than brush replacement should be performed by an authorized service representative.

Use of any accessories or attachments other than those supplied by KAM CONTROLS may be hazardous.